

ROTAX 914 UL - DCDI

ROTAX 914 UL - DCDI

Info Pak
Part No. 999-680

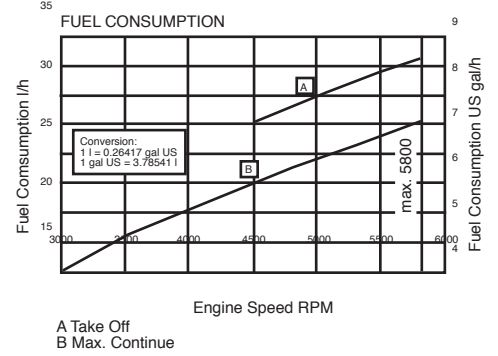
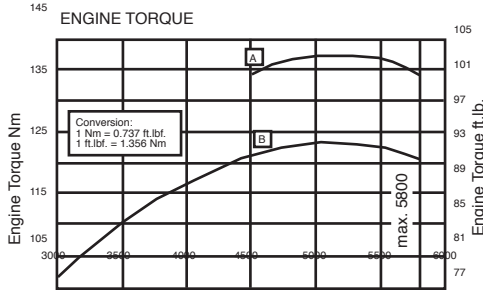
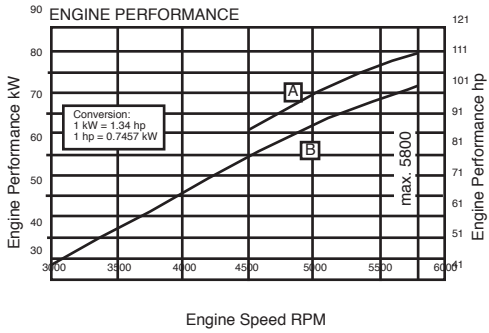

ROTAX 914 UL - DCDI

4-Cylinder, 4-Stroke liquid/air cooled engine with opposed cylinders, with turbo charger, with automatic waste gate control, dry sump forced lubrication with separate 3 liter (.8 gal US) oil tank, automatic adjustment by hydraulic valve tappet, 2 CD carburetors, electronic dual ignition, electric starter, integrated reduction gear $i = 2.43$, engine truss assembly, air intake system, exhaust system.

VERSION	PERFORMANCE			TORQUE			MAX RPM
	kW	hp	1/min.	Nm	ft. lb.	1/min.	
914 UL	73.5	100	5500	144	106	4900	5800
max. 5 min.	84.5	115	5800				
BORE		STROKE		DISPLACEMENT		COMPRESSION RATIO	
79.5 mm 3.13 in.		61 mm 2.4 in.		1211.2 cm ³ 73.91 cu. in.		9.0:1	
FUEL		OIL		COOLING LIQUID			
min. MON 85 RON 95* min AKI 91*		API SF or SG		50% BASF Glysanthin Anitcorrosion 50% Water			
* leaded or unleaded or AVGAS 100 LL							
IGNITION UNIT		IGNITION TIMING		SPARKPLUG			
DUCATI double CDI		4° up to 1000 RPM 1/min above 26°/22°		ROTAX Part No. 897-257			
GENERATOR PERFORMANCE		RPM		VOLTAGE			
250 W DC		5500 1/min		13.5 V			
		WEIGHT					
STANDARD		kg		lb			
Engine with gearbox $i = 2.43$		64.0		141.0			
Exhaust System		4.0		8.8			
Engine Truss Assembly		2.0		3.7			
OPTIONS		kg		lb			
Slipping Clutch		1.7		3.7			
Oil Radiator Part No. 886-029		0.5		1.1			
Radiator Part No. 995-697		1.0		2.2			
Air Cleaner Part No. 825-750		0.15		0.3			
Air Guide Hood		0.8		1.8			
Vacuum Pump		0.8		1.8			
Hydraulic Propeller Governor		2.7		5.9			
Rectifier Regulator		0.1		0.2			
Instrument FLYdat		0.5		1.1			
Recall Instrument RDAT		1.0		2.2			
External Alternator 40A/12V		3.0		6.6			

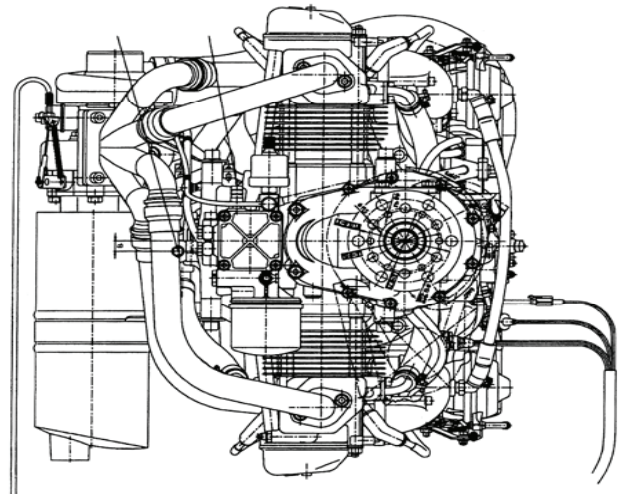
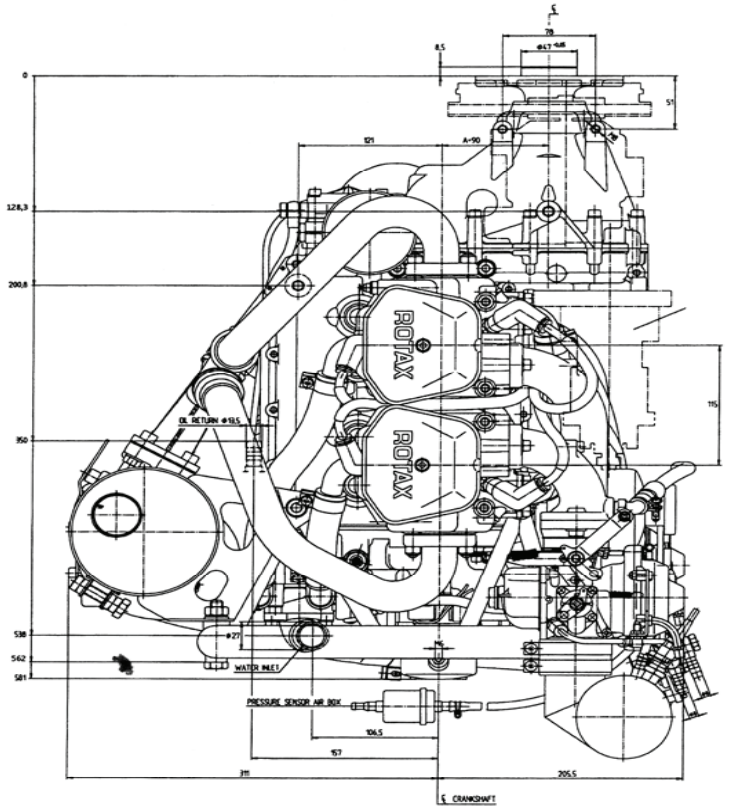

TBO ON NEW 914 UL

ROTAX ENGINES IS 1200 hrs.

You can also upgrade the following existing serial numbers
4,418.104 and higher.

Please call our engine shop for pricing.

LEADING EDGE AIR FOILS, LLC
CUSTOMER SERVICE 1-262-763-4087 FAX 1-262-763-1920

independent SERVICE CENTRE

ROTAX
AIRCRAFT ENGINES