

# ROTAX 277 UL - 26 hp Fan Cooled 6250 RPM

(Please Note: The ROTAX 277 Engine is No Longer in Production)

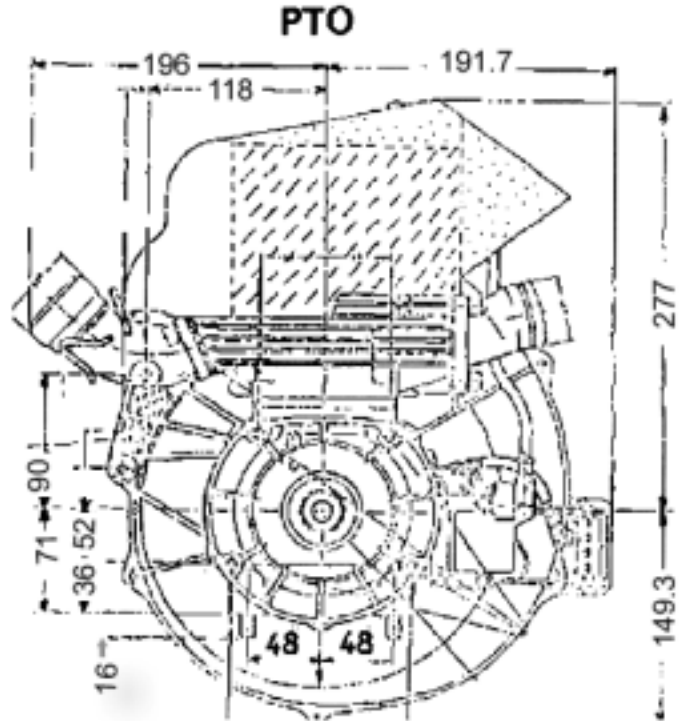
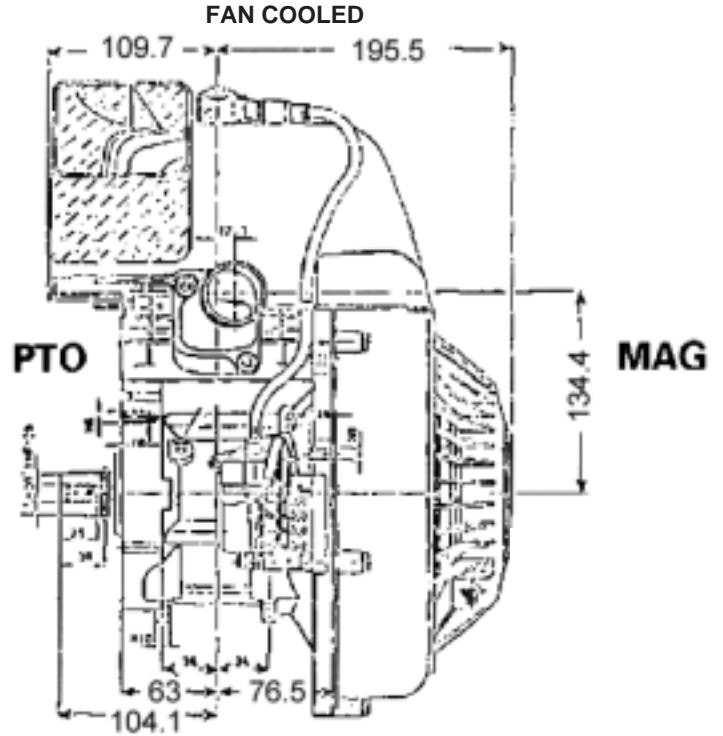
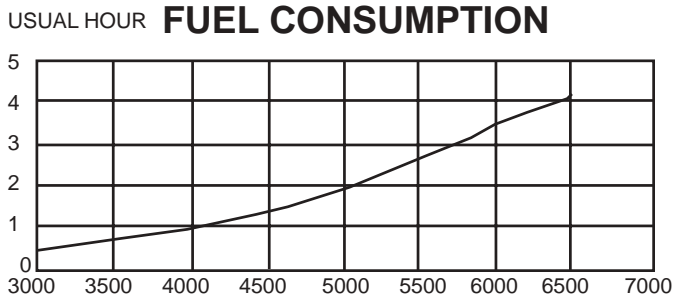
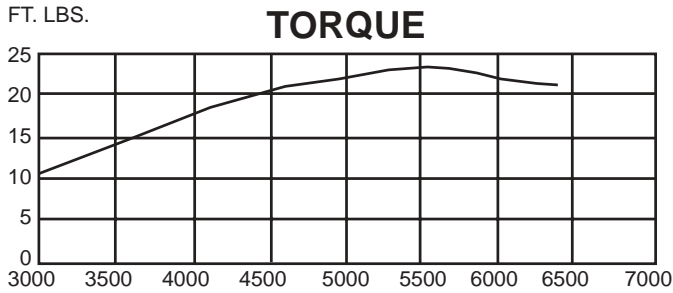
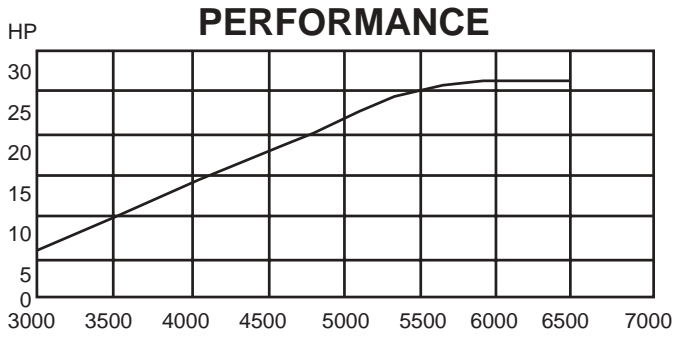

**ROTAX 277 - 26 hp - 6250 RPM  
1 Cylinder/ 2 - Stroke Piston Ported**

**Bore/Stroke:** 72/66 mm

**Displacement:** 268.7

**Ignition System:** Bosch Flywheel Magneto Generator  
12V 75/23W

**Carburetor:** 36 mm Bing Double Float Carburetor  
with hand lever or alternatively cable choke.

**Starter:** Rewind or Electric

**Cooling:** Free Air or Fan Cooled

**Lubrication:** Oil in fuel, 2-stroke oil; mixing ratio: 50:1

**Fuel:** Premium Unleaded; Not below MON 88 or  
RON 90 (octane rating)

Description	Weight
Block F.C. ....	42.0 lbs.
Carburetor .....	2.5 lbs.
Exhaust .....	10.0 lbs.
Redrive .....	10.5 lbs.
<b>Total Weight</b> .....	<b>65.0 lbs.</b>



**LEADING EDGE AIR FOILS, LLC 1-800-532-3462 info@leadingedgeairfoils.com**  
[www.leadingedgeairfoils.com](http://www.leadingedgeairfoils.com) [store.leadingedgeairfoils.com](http://store.leadingedgeairfoils.com)