

Rotax 503 UL DCDI - 2 Cycle 2-Stroke

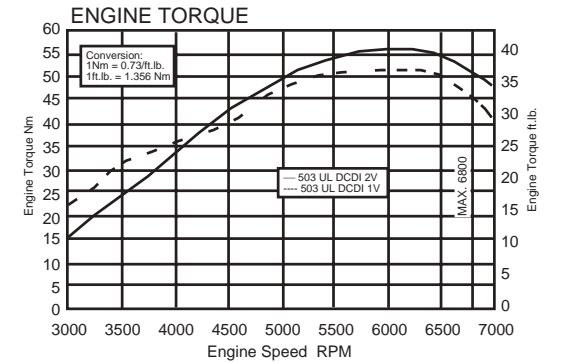
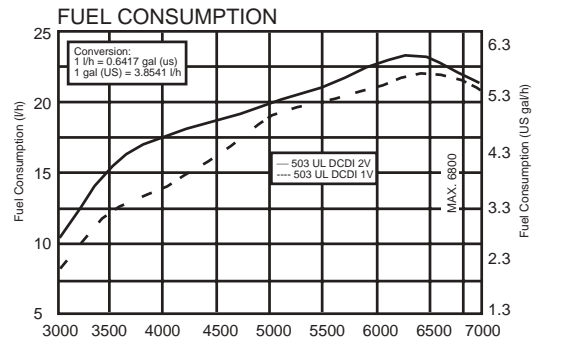
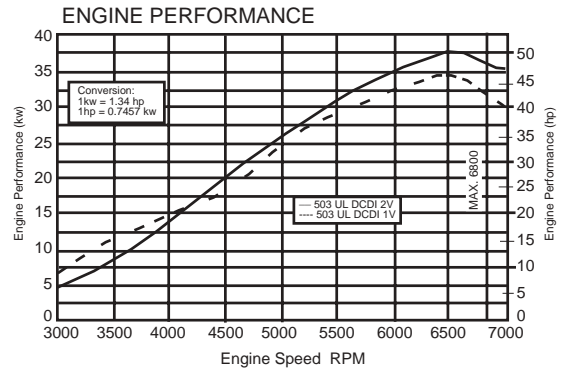
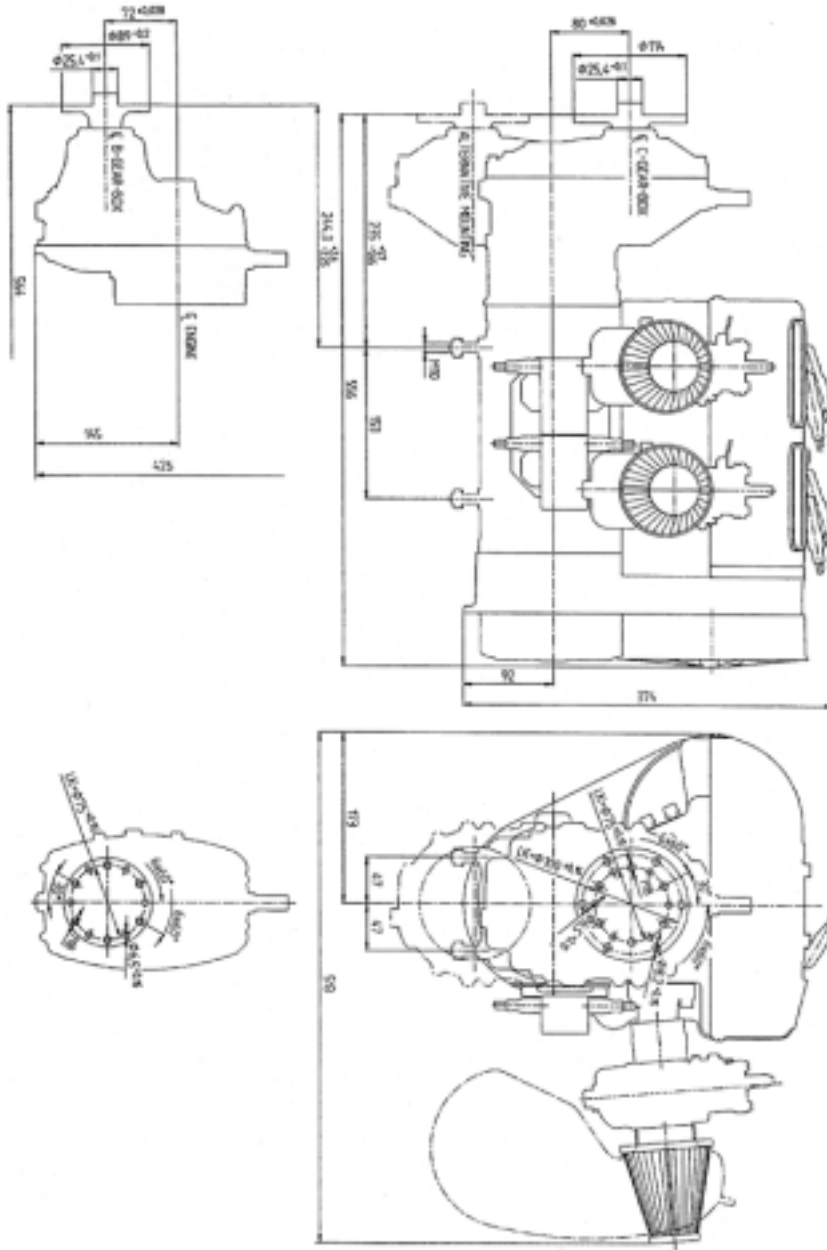

2-cycle, 2 stroke fan cooled engine with piston ported inlet with electronic dual ignition, exhaust system, carburetor, rewind starter.

Version	Performance			Torque			Max. RPM
	kW	hp	1/min.	Nm	ft. lb.	1/min.	
503 UL-1V	34.0	45.6	6500	51	37.6	5900	6800
503 UL-2V	37.0	49.6	6500	56	41.3	6000	6800

Bore	Stroke	Displacement		Compression Ratio	
72 mm 2.84 in.	61 mm 2.40 in.	496.7 cm ³	30.31 cu.in.	th: 10.8	ef: 6.2

Fuel	Super 2-Stroke Oil	Mixing Ratio
min. MON 83 RON 91* min. AKI 87*	API-TC-Classification	1:50**

*Leaded or unleaded **Variable with fresh oil pump

Ignition Unit	Ignition Timing	Spark Plug
Ducati double CDI	16° v. OT	ROTAX P/N 897-055

Generator Performance	RPM	Voltage
155 W DC	6000 1/min	13.5 V

Standard

	kg	lb
Engine*	31.4	69.2
2 Carburetors	1.8	4.0
Exhaust System	5.1	11.2

Options

	kg	lb
2 Air Cleaners	0.3	0.7
Dual Air Cleaner	0.5	1.1
Electric Starter	3.5	7.7
Gearbox "B"/i=2.0/2.24/2.58	4.5	9.9
Gearbox "C"/i=2.62/3.0/3.47/4.0	8.0	17.6
Gearbox "E"/i=2.62/3.0/3.47/4.0	11.2	24.7
External Alternator 220 W DC	1.1	2.4
Oil Tank 2.4 l	1.6	3.5
Fresh Oil Pump	0.3	0.7
HAC Kit	0.2	0.4
Intake Silencer 1V	0.8	1.8
Intake Silencer 2V	1.1	2.4
After Muffler	1.6	3.5

*Engine also available in free air version