

ROTAX 582 UL - D.C.D.I. Mod. 99

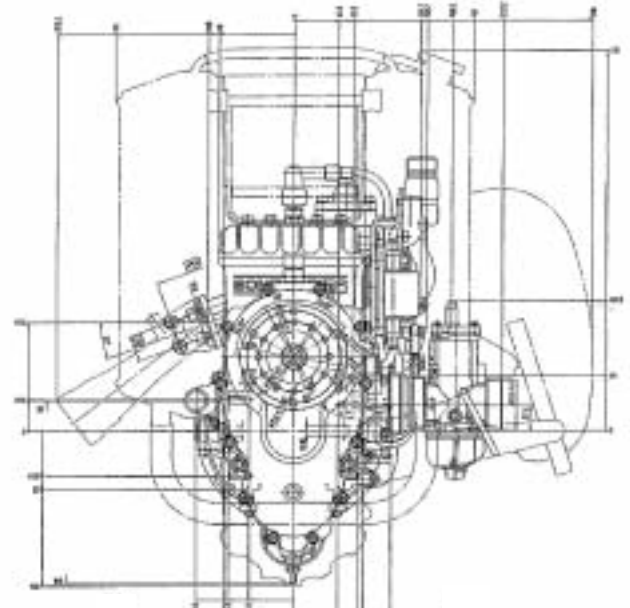
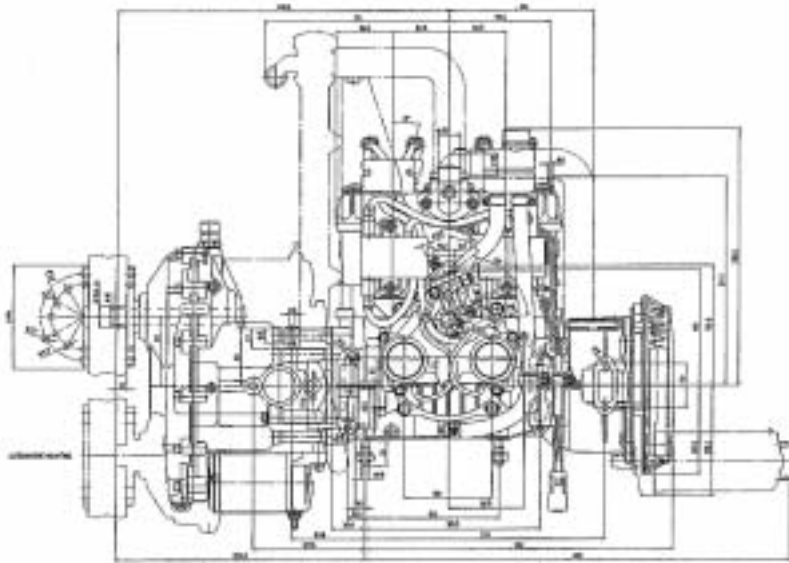

582 UL-D.C.D.I. Mod 99

2-cylinder 2-Stroke liquid cooled engine with rotary valve inlet, with electronic dual ignition, integrated water pump and thermostat, exhaust system, carburetor, rewind starter.

Version	Performance		Torque		Max. RPM
	kW	hp	1/min.	Nm	ft. lb.
582 UL-2V	48	65.0	6500	75	55.3
				6000	6800
Bore	Stroke	Displacement		Compression Ratio	
76 mm 2.99 in.	64 mm 2.52 in.	580.7 cm ³	35.44 cu. in.	th:11.5 ef:5.75	
Fuel		Super 2-Stroke Motoroil		Mixing Ratio	
min. MON 83 RON 91*		API-TC-Classification		1:50**	
min. AKI 87*					
*Leaded or Unleaded		**Variable with fresh oil pump			
Igniton Unit	Ignition Timimg		Spark Plug		
Ducati double CDI	18° v. OT		Rotax P/N 897-055		
Generator Performance		RPM	Voltage		
155 W DC		6000 1/min	13.5 V		
Description		Weight kg	Weight lb		
Engine		29.1	64.0		
2 Carburetors		1.8	4.0		
Exhaust System		5.1	11.2		
Double Air Filter		0.3	0.7		
Electric Starter		3.5	7.7		
Gearbox "B"/i = 2.0/2.24/2.58		4.5	9.9		
Gearbox "C"/i = 2.62/3.0/3.47/4.0		8.0	17.6		
Gearbox "E"/i = 2.62/3.0/3.47/4.0		11.2	24.7		
External Alternator 220 W DC		1.1	2.4		
2 Radiators Big		2.2	4.9		
Radiator 995-697		1.0	2.2		
Expansion Tank 922-317		0.3	0.7		
Overflow Bottle 922-325		0.2	0.4		
Fresh Oil Pump		0.1	0.2		
Oil Tank 2.4 l		0.6	1.3		
HAC-kit		0.2	0.4		
Intake Silencer 2V		1.1	2.4		
After Muffler		1.6	3.5		
Instrument FLYdat		0.5	1.1		
Recall Instrument RDAT		1.0	2.0		

ENGINE PERFORMANCE

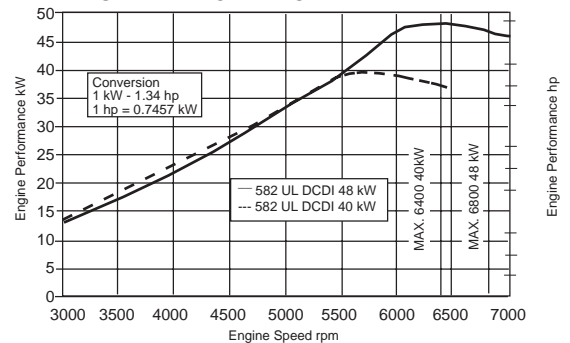

ENGINE TORQUE

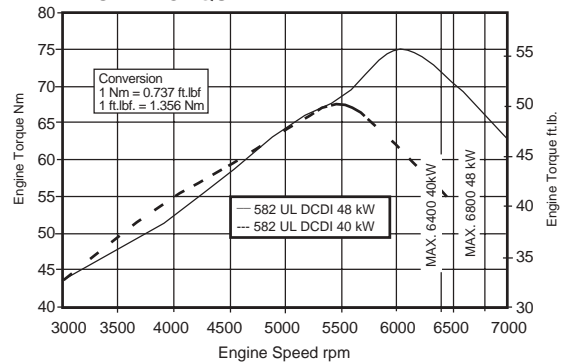

FUEL CONSUMPTION

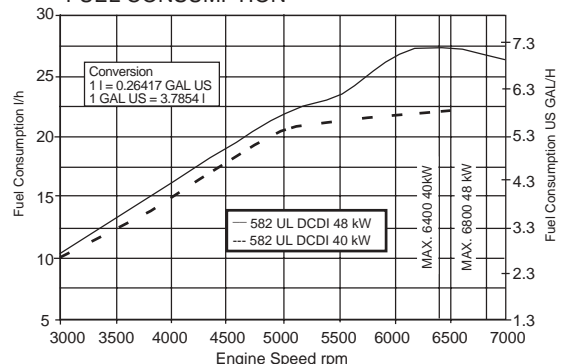

LEADING EDGE AIR FOILS, LLC 1-800-532-3462 info@leadingedgeairfoils.com
www.leadingedgeairfoils.com store.leadingedgeairfoils.com